

迴轉圓錐式混合機

ROTARY CONE MIXER

特性

1. 適用於比重不同之粉碎或其他添加物之混合。
2. 採用內外迴轉攪拌，均勻度高。
3. 混合桶可任意傾斜角度，便於出料及清潔之需要。
4. 設有自動定時裝置，可設定0-60分鐘自動停止。
5. 操作簡單，容易清洗，適合G.M.P食品、藥廠使用。

FEATURE

1. This machine can mix all powder of different specific gravity well.
2. The machine adopt outer-inner rotation and grain of powder is uniform.
3. The mixing barrel can be tilted freely at the angle of degrees for discharging and cleaning purpose.
4. The automatic stopping device can be set within the range of 0-60 minutes.
5. Easy to operate, easy to wash, clean and move. it is very suitable for GMP food and pharmaceutical factories.

RC-300

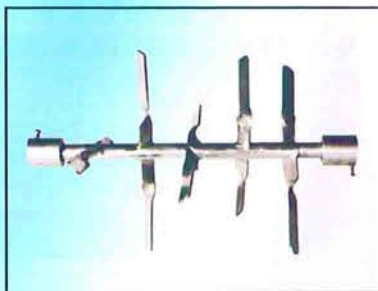

攪拌葉片
Mixing Wing

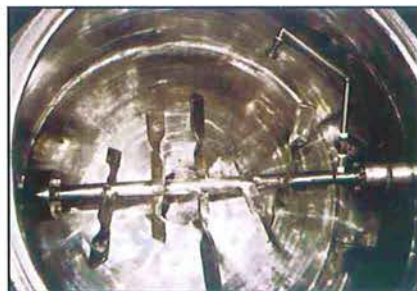

內部噴油裝置
Inner Oil Spraying Device



加裝噴油裝置
With Oil Spraying Device

G
R
E
A
T
E
D
M
I
L
L
&
M
I
X
E
R



ROTARY CONE MIXER



Inner Blade



Inner Blade with Oil Spraying Device



Inner (Fixed Plate)



FEATURE

- **The outer** barrel and inner blades are being controlled by separate motors which enhance mixing strength, and having different rotating direction in order to have excellent homogeneous mixing.
- **It is** designed to be tilted freely at angle 0°-360° degrees. In addition to manual opening inlet and outlet, it can be customized with pneumatic control.
- **Fully** stainless steel polished finishing meeting GMP requirement without dead angle. Oil / Liquid spreading device is optional.
- **Water** proof control box, digital timer, overload protector device, ampere and voltage meter are included.

SPECIFICATION

APPLICATION

Suitable for mixing powder ingredients in different gravity, and a little amount of additive. Pharmaceutical, Western / Herbal Medicine, Biotech, Healthy Food and... etc.

FLOWCHART

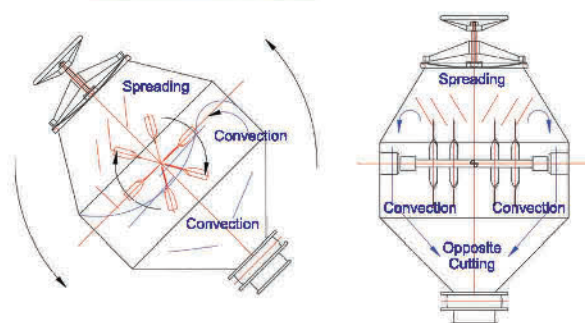

Model	Volume (kg/L)	HP (kw)		Dimension (LxWxH mm.)
		Shaft	Outer-Barrel	
RC-50	50/120	1	2	1800x750x1560
RC-100	100/260	2	3	1900x880x1700
RC-200	200/500	2	3	2300x1200x1900
RC-300	300/700	3	5	2430x1300x2100
RC-500	500/1200	3	7 1/2	2800x1450x2400
RC-1000	1000/2400	5	15	3500x1700x2700
RC-2000	2000/5000	15	25	4100x2000x3400
RC-3000	3000/7000	20	40	4500x2500x4600

※From floor to outlet: 450 mm.

混合示意圖

(Mixing principle instuction)

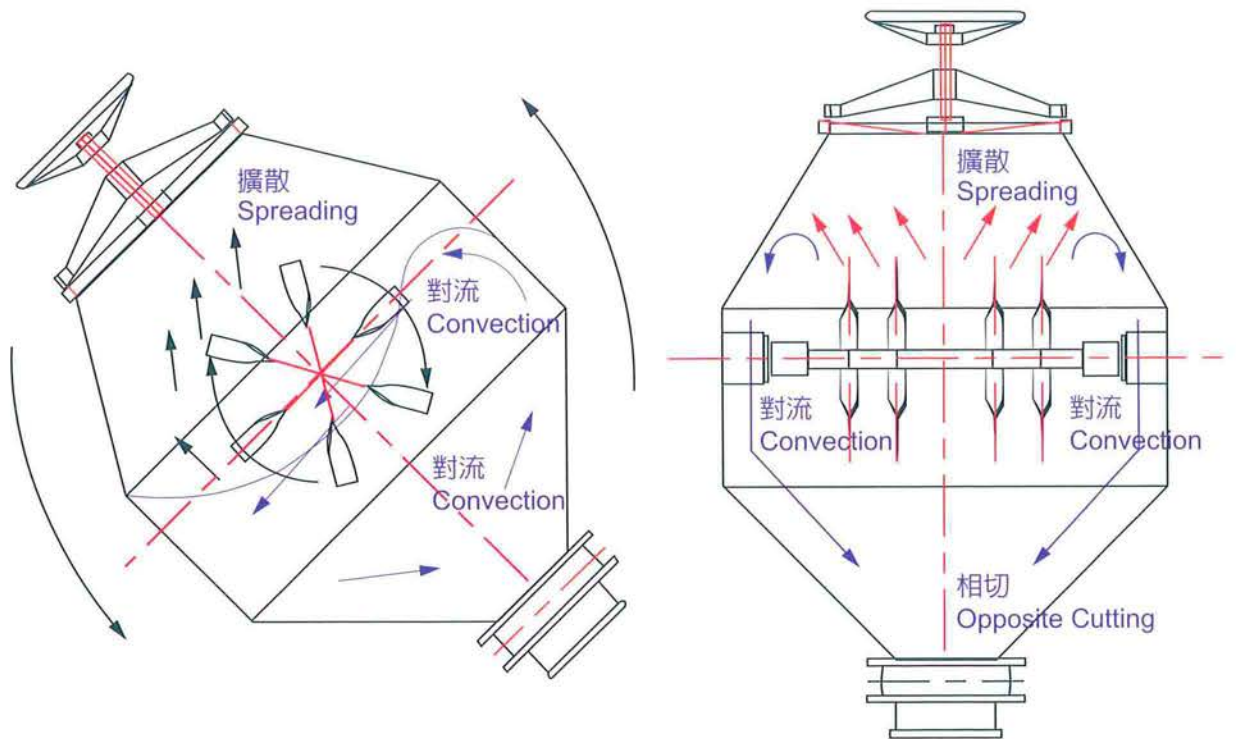

型式	容量	馬力		機械尺寸
Model	Full Volume(KG/L)	主軸 Shaft	外桶 Outer-Barrel	Dimension(m/m)
RC-50	50/120	1	2	1800×750×1560
RC-100	100/260	2	3	1900×880×1700
RC-200	200/500	2	3	2300×1200×1900
RC-300	300/700	3	5	2430×1300×2100
RC-500	500/1200	3	7 1/2	2800×1450×2400
RC-1000	1000/2400	5	15	3500×1700×2700
RC-2000	2000/5000	15	25	4100×2000×3400
RC-3000	3000/7000	20	40	4500×2500×4600

出口離地面高度(From Floor To Outlet):450m/m